

## About Us



Woerner Industries, Inc. has manufactured and installed pew seating for over 85 years. We are located in Rochester, New York and have a history of working with churches in satisfying their seating needs.

While we have some of the most modern woodworking equipment available, we still employ many of the same manufacturing techniques and quality standards used by our craftsmen 50+ years ago.

We specialize in solid wood pews, with wood or padded seats and backs. We offer a complete line of pews and accessories. All of our designs can be customized to meet your needs. Pews are available in Northern red oak (standard), white oak, cherry, maple, birch, walnut, and mahogany. Upholstered seats and backs are removable for later reupholstering.

Many of our projects involve custom pews. We specialize in projects which require refurbishing and/or manufacturing new pews to match existing pews.

## Wood Finishes



Light Oak

Harvest Oak

Fruitwood

Amber

Medium Oak

Rosewood

Limed Oak

Antique Cheery

Walnut

Pecan

Natural Oak

Dark Oak

Golden Oak

Sienna

Mahogany

Sunset

Please Note: Actual finished pieces will exhibit some variation in grain and tone due to the natural characteristics of wood and no guarantee can be made of an exact match.

Actual wood samples are available upon request. Custom finishes are available for an additional charge.

## Fabrics

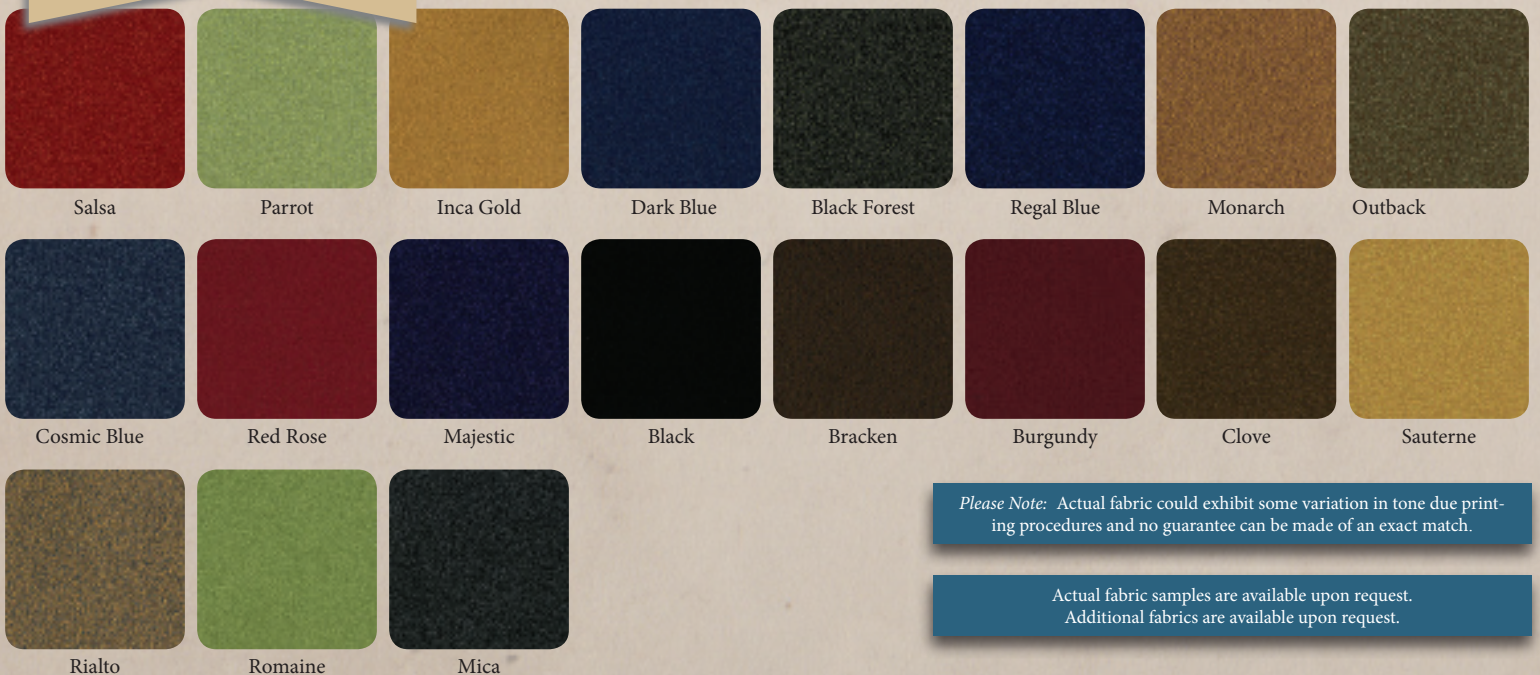

Salsa

Parrot

Inca Gold

Dark Blue

Black Forest

Regal Blue

Monarch

Outback

Cosmic Blue

Red Rose

Majestic

Black

Bracken

Burgundy

Clove

Sauterne

Rialto

Romaine

Mica

Please Note: Actual fabric could exhibit some variation in tone due printing procedures and no guarantee can be made of an exact match.

Actual fabric samples are available upon request. Additional fabrics are available upon request.



Pew seats, backs and ends can be manufactured in various combinations to meet your specific requirements. We offer three basic pew body designs which follow:

### 101 Solid wood seat and back

Seats are machined from 6/4 lumber (1.50" raw lumber thickness). Final thickness will be approximately 1-3/16". Seats have a scooped out contoured area for comfort. Boards are glued up with tongue and groove construction. Seats are reinforced underneath with a 1.5" thickness x 2.5" height lateral brace.

Backs are machined from 4/4 lumber (1" raw lumber thickness). Final thickness will be approximately .75". Boards are glued up with tongue and groove construction. The cap rail is fastened to the pew back with tongue and groove construction.

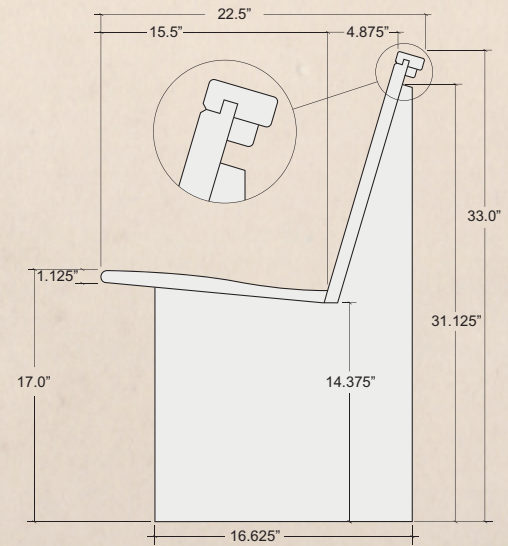
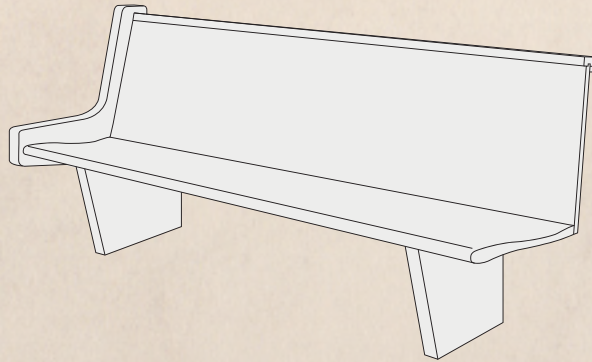

### 102 Padded seat and wood back

Seats are manufactured with a .75" veneer core plywood base with solid poplar rails across the front and back for support and anchoring. Foam is 4" thickness with 2.6# density and 45 - 48# compression ratio. Many fabrics are available for a covering.

Backs are machined from 4/4 lumber (1" raw lumber thickness). Final thickness will be approximately .75". Boards are glued up with tongue and groove construction. The cap rail is fastened to the pew back with tongue and groove construction.

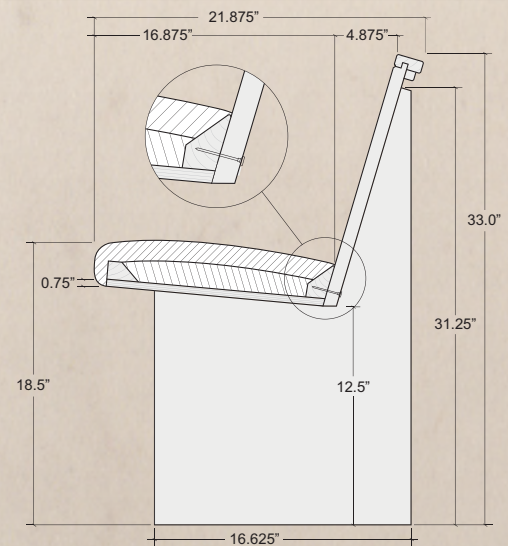
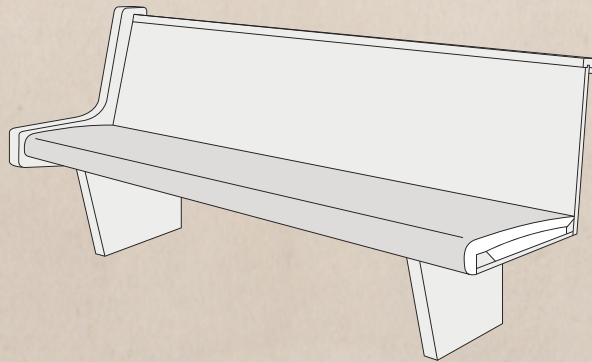

### 103 Padded seat and back

Seats are manufactured with a .75" veneer core plywood base with solid poplar rails across the front and back for support and anchoring. Foam is 4" thickness with 2.6# density and 45 - 48# compression ratio. Many fabrics are available for a covering.

Backs are machined from 4/4 lumber (1" raw lumber thickness). Final thickness will be approximately .75". Boards are glued up with tongue and groove construction. The cap rail is fastened to the pew back with tongue and groove construction. The front of the pew back is covered with 1" foam and fabric which are removable for recovering at a future date.

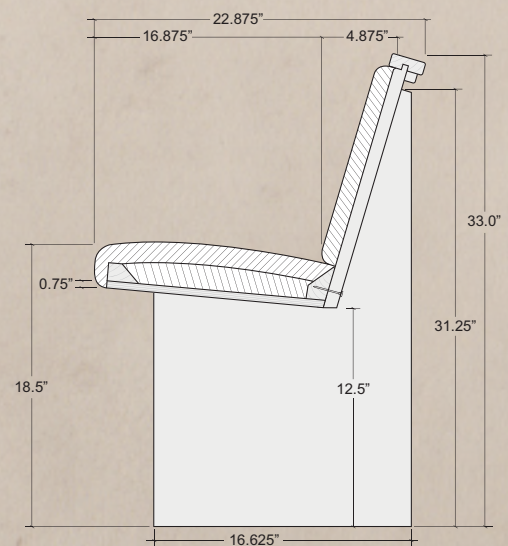
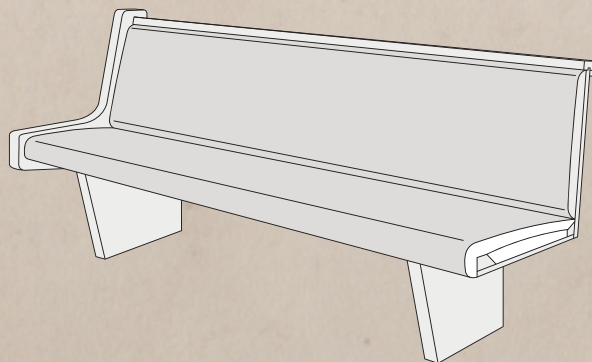



## Edge Detail

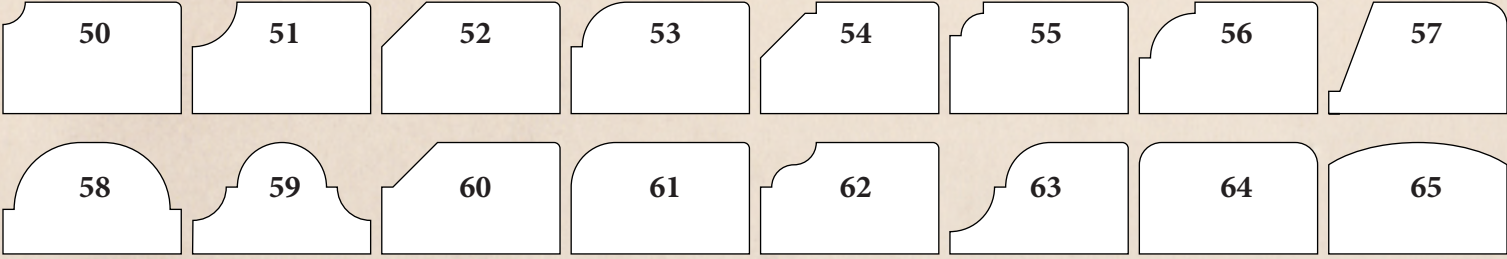

## Pew Ends

Pew ends are solid red oak, 2” thickness with butcher block or two-ply construction. Full pew ends have a separate 3” high foot glued, doweled and screwed to the pew end. This provides the support for anchoring to the floor. Pew ends are anchored to the floor with concealed fasteners, one per end. Two anchors are also available upon request.

Pew supports are solid red oak, two-ply 1.5” thickness. Each panel is .75” thickness.

Following are standard Woerner pew ends. Custom designs are available upon request.



526 Pew End



530 Pew End



576 Pew End

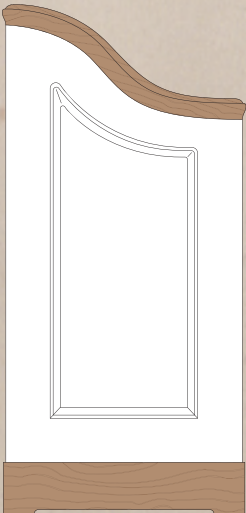

585 Pew End

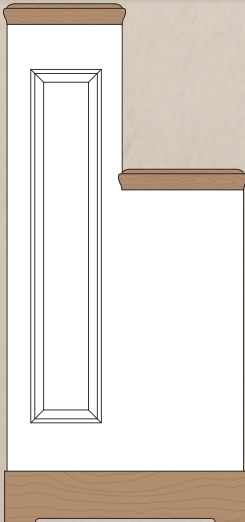

564 Pew End

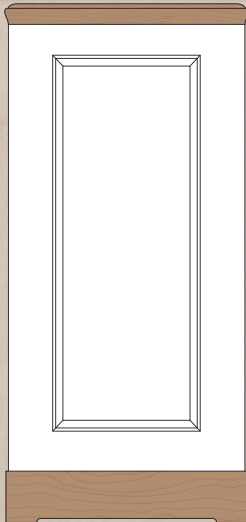

563 Pew End

(Note: 585, 564, and 563 are also available without white finish)

**Pew Ends**

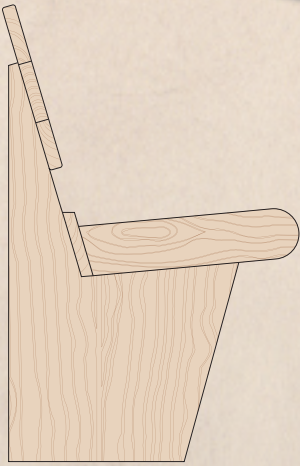

**556 Pew End**

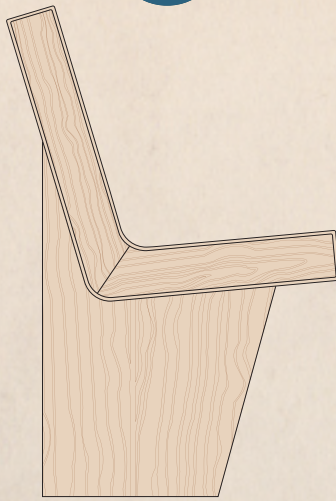

**532 Pew End**

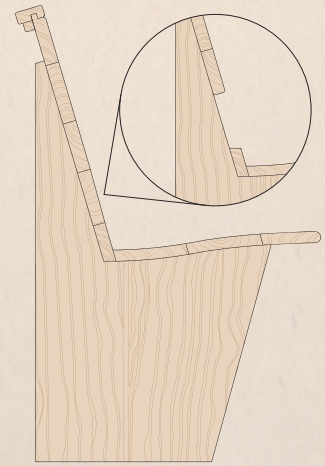

**555 Pew End**  
Available with a fully closed back or an opening across the bottom of the backrest

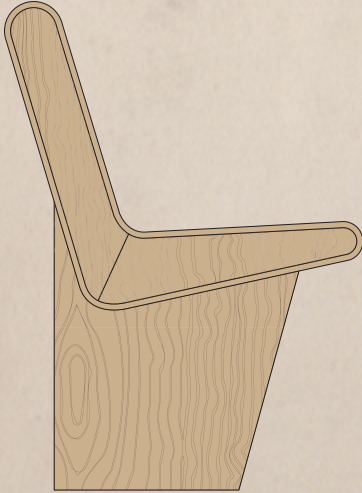

**571 Pew End**

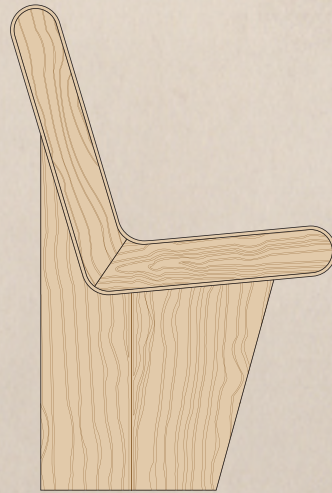

**580 Pew End**

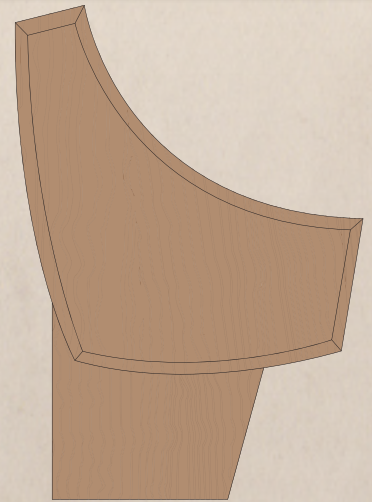

**587 Pew End**

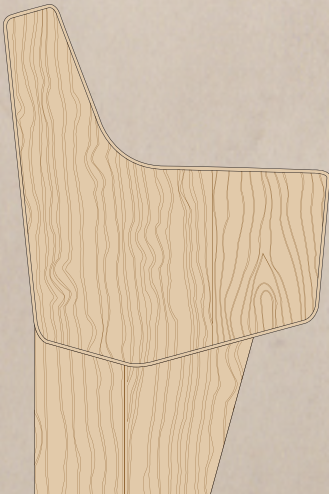

**573 Pew End**

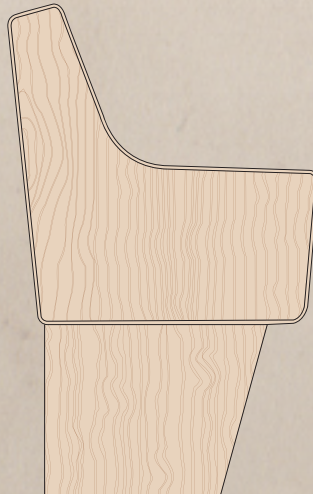

**527 Pew End**

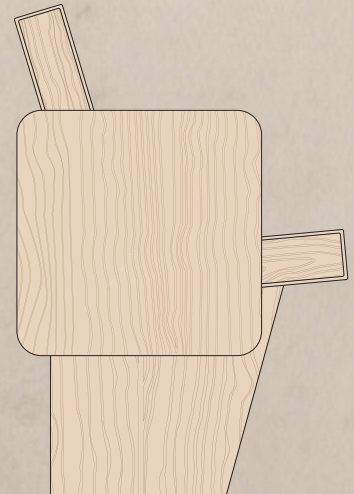

**539 Pew End**

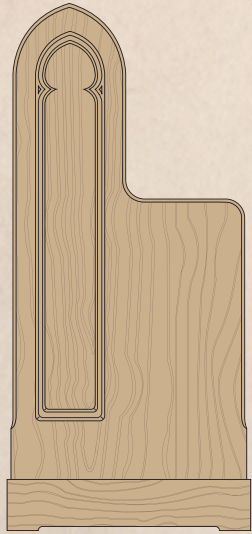

549 Pew End

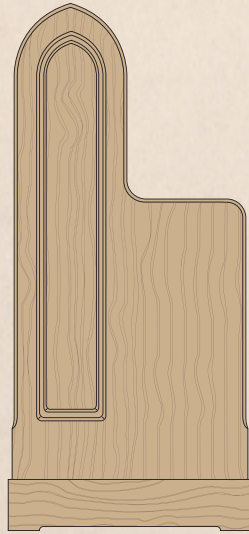

542 Pew End

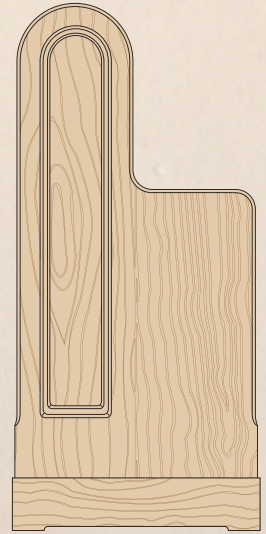

551 Pew End

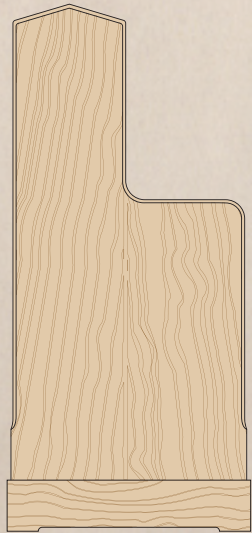

541 Pew End

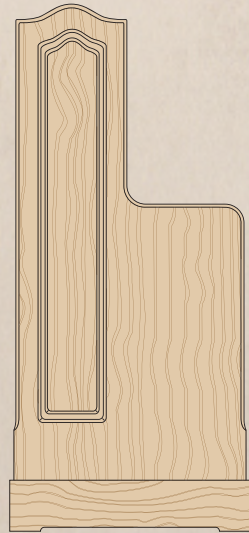

578 Pew End

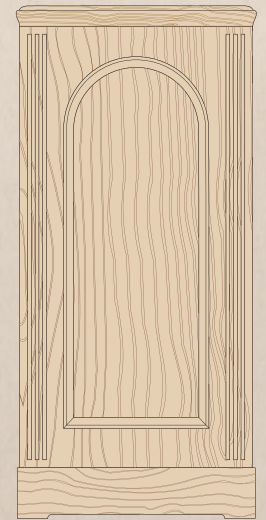

584 Pew End

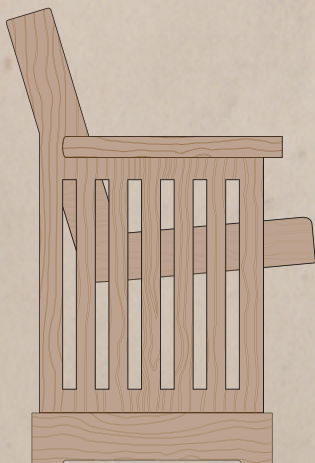

533 Pew End

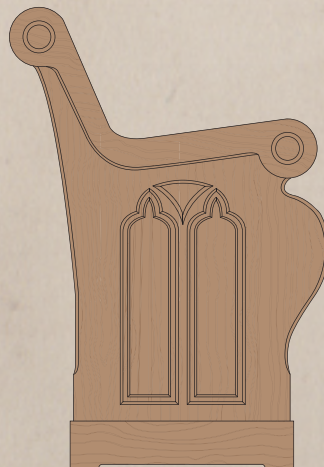

577 Pew End

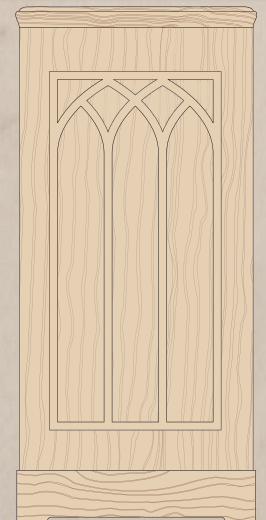

546 Pew End



## Pew Accessories



**4228 Hymn Book Rack**  
Outside: 20" w x 11" h  
Inside: 18-1/2" w x 2-1/4" d

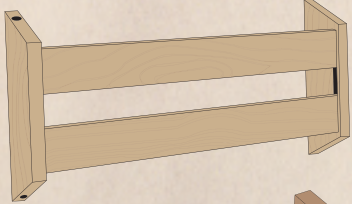

**4224 Hymn Book Rack**  
Unfinished  
**4225 Hymn Book Rack**  
Outside: 20" w x 9" h  
Inside: 18-1/2" w x 2-1/4" d



**4227 Hymn Book Rack**  
Outside: 20" w x 4-1/2" h  
Inside: 18-1/2" w x 1-7/8" d

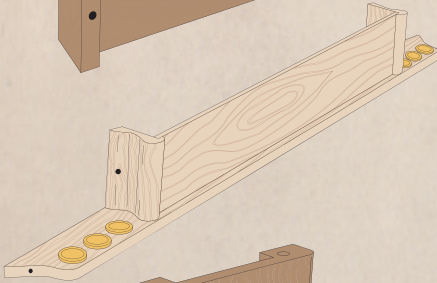

**253 Hymn Book Rack**  
w/6 cup holders.  
Interior: 24" w x 2" d

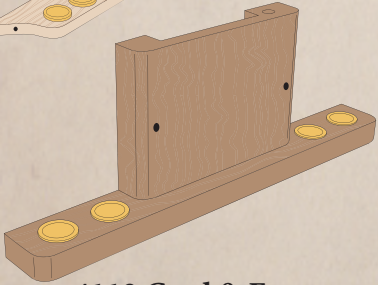

**4113 Card & Four Cup Holder**  
13" w x 1-1/2" d,  
4-5/8" h. Cup silencers included



**4104 Communion Cup Holder**  
7" w x 1-3/4" d, 3/4" h. Cup silencers included

*Note: Custom sizes available at additional cost. Card holders are made of solid oak with rounded edges. Holds pencils, cards, or envelopes. All hardware included.*

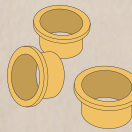

**4107 Communion Cup Silencer**  
Fits 1" diameter hole, made of plastic.

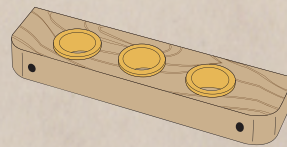

**4105 Communion Cup Holder**  
8" w x 1-3/4" d, 3/4" h. Cup silencers included

**4226 Hymn Book Rack**  
Outside: 20" w x 4-1/2" h  
Inside: 18-1/2" w x 1-7/8" d



**258 Underseat Book Rack**  
Interior: 18" w x 6-5/8" d, 2-1/4" h

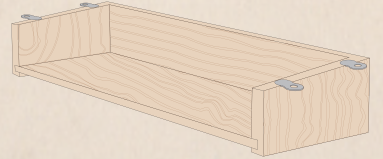

**255 Hymn Book Rack**  
Self cleaning style.  
Interior: 18" w x 2-1/4" d

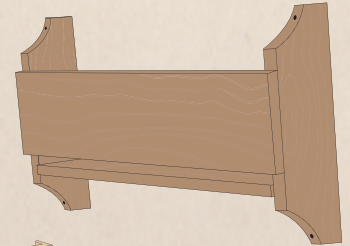

**257 Hymn Book Rack**  
Interior: 20" w x 2-1/4" d

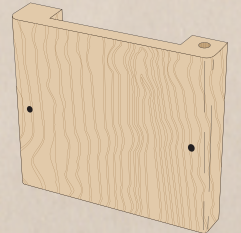
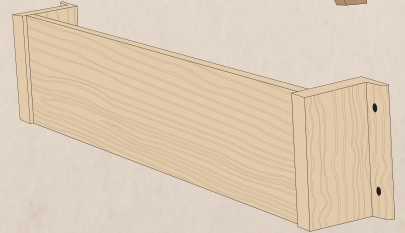

**4100 Card Holder**  
6" w x 1" d, 5" h  
Opening for card:  
3-1/2" w x 5/8" d, 4" h

## Pew Kneelers

Most of our projects include wood frame kneelers, but we also offer metal frame kneelers if the need arises. Wood kneelers have 1" thick ends and 1-1/4" 6# density foam over a 3/4" plywood cushion board. Standard depth on kneeler pads is 5" with a height from the floor of 7-3/8".

